

# INSTALLATION INSTRUCTIONS

**WARNING: NEVER EXCEED YOUR VEHICLE MANUFACTURER'S RECOMMENDED TOWING CAPACITY**

## ADJUSTABLE TRI-BALL MOUNT

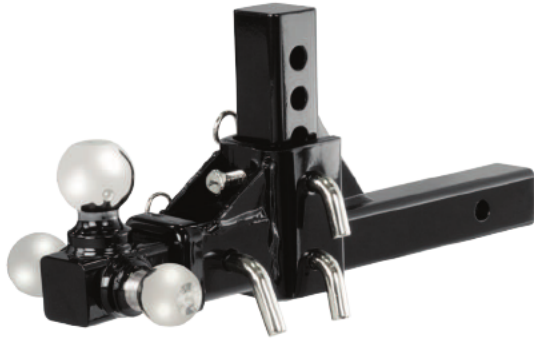

### PARTS LIST

Item	Qty	Description
1	4	Hitch pin
2	4	Clip
3	1	Shank assembly
4	1	Ball mount weldment
5	1	Anti-rattle bolt, 1/2" - 13, 1", grade 5
6	1	Receiver tube assembly

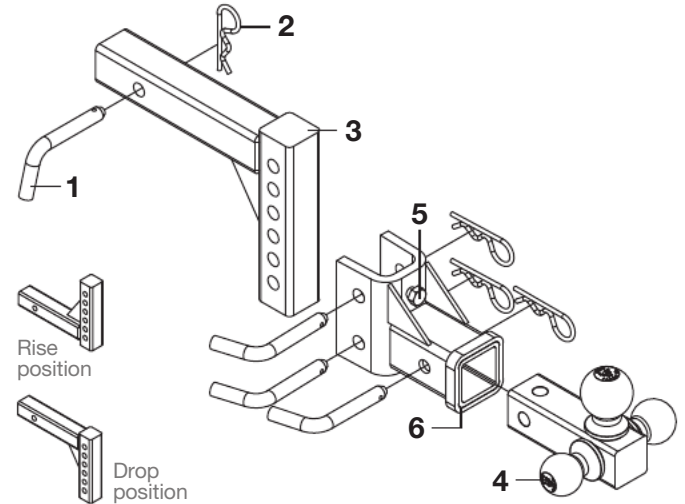

### INSTALLATION

Prior to installation, assemble this unit so trailer will be level when hitched to tow vehicle.

#### Step 1

Insert the shank assembly (#3) into the receiver hitch and install the hitch pin & clip (#1 and #2). **Note:** Flip the shank assembly over for rise adjustments.

#### Step 2

Secure the receiver tube assembly (#6) to the shank assembly (#3) using two 5/8" hitch pins & clips (#1 and #2).

#### Step 3

Tighten the anti-rattle bolt (#5) to eliminate movement between the shank assembly and the receiver tube assembly.

#### Step 4

Insert ball mount weldment (#4), with required ball size pointing upward, into the receiver tube assembly (#6) and secure with a hitch pin & clip (#1 and #2).

Always attach safety chains between the trailer and tow vehicle.

### WARNINGS

Do not exceed vehicle's towing capacity or trailer hitch capacity, whichever is less. See your vehicle owner's manual to determine vehicle tow rating.

Weight ratings:

#### 1 7/8" ball

5,000 lbs. gross trailer weight / 500 lbs. tongue weight

#### 2" ball

7,500 lbs. gross trailer weight / 750 lbs. tongue weight

#### 2 5/16" ball

10,000 lbs. gross trailer weight / 1,000 lbs. tongue weight

### NOTES

Designed for use with class 4 and 5 hitches.

Periodically check your tow system to ensure that all fasteners are tight and that all structural components are sound.